

**HF-H2
Heat Detector**

Heat Detector supports the HF-Link communication mode to communicate with the fire alarm gateway, which can sense the environment.

- Support constant temperature alarm: indoor ambient temperature, greater than 57 ° C alarm.
- Support differential temperature alarm: indoor ambient air temperature changes about ≥ 8 °C/min alarm.
- Support buzzer alarm, sound pressure 45 dB~75 dB@3 m.
- Lithium battery power supply, the average theoretical design life of 3 years.
- Support anti-disassembly, low voltage, sensor fault alarm.
- Support signal strength query, easy deployment and installation.
- Support test, local and remote mutting.

▪ Specification

Detector	
Alarm current	≤ 15 mA
Alarm mode	Audible alarm
Alarm sound level	75 dB@3 m (A weighting)
Temperature Sensing Mode	Thermistor
General	
Quiescent Current	≤ 10 μA
Dimension (φ × H)	Φ 120 mm × H 56 mm
Battery Life	3 years
Power supply	DC 3 V
Weight	150 g
Input Working Voltage	DC 3V, lithium battery CR17450 (with throwing wire)
Wireless Communication	LoRa,433MHz

▪ Dimension

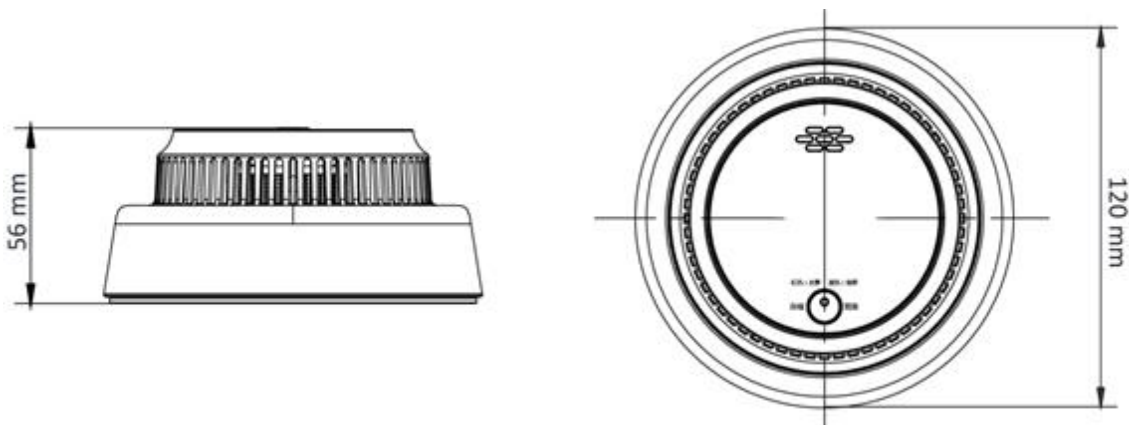

See Far, Go Further



www.hikvision.com
support@hikvision.com

