

**HF-GP110
Gas Detector**

The Standalone Liquefied Petroleum Gas Alarm provides the When the natural gas leakage in the protected area reaches the alarm concentration

- Support multiple function, alarm, test, silence, fault and malfunction.
- Support log saving function, record alarm, alarm recovery, fault, fault recovery, sensor failure and other types of logs.
- Support valve output and fan output.

▪ Specification

Detector	
Alarm Volume	70dB~115dB @1m(A-weighted)
gas type	C3H8
Measuring range	0~25%LEL
Function	
Alarm threshold	10%LEL
Interface	
Output Signal	1-way solenoid valve output interface, 1 way exhaust fan output interface
General	
Working principle	Catalytic combustion
Power supply	AC 220 V
Protection Level	IP 30
Environment	Temperature: -10 °C ~ 55 °C; Humidity: ≤93% (40 °C、non-condensing)
Dimension (φ × H)	122 mm × 77 mm × 34 mm
executive standard	GB 15322.2-2019

▪ Available Model

HF-GP110

HF-GP110(IN-STD)

▪ Dimension

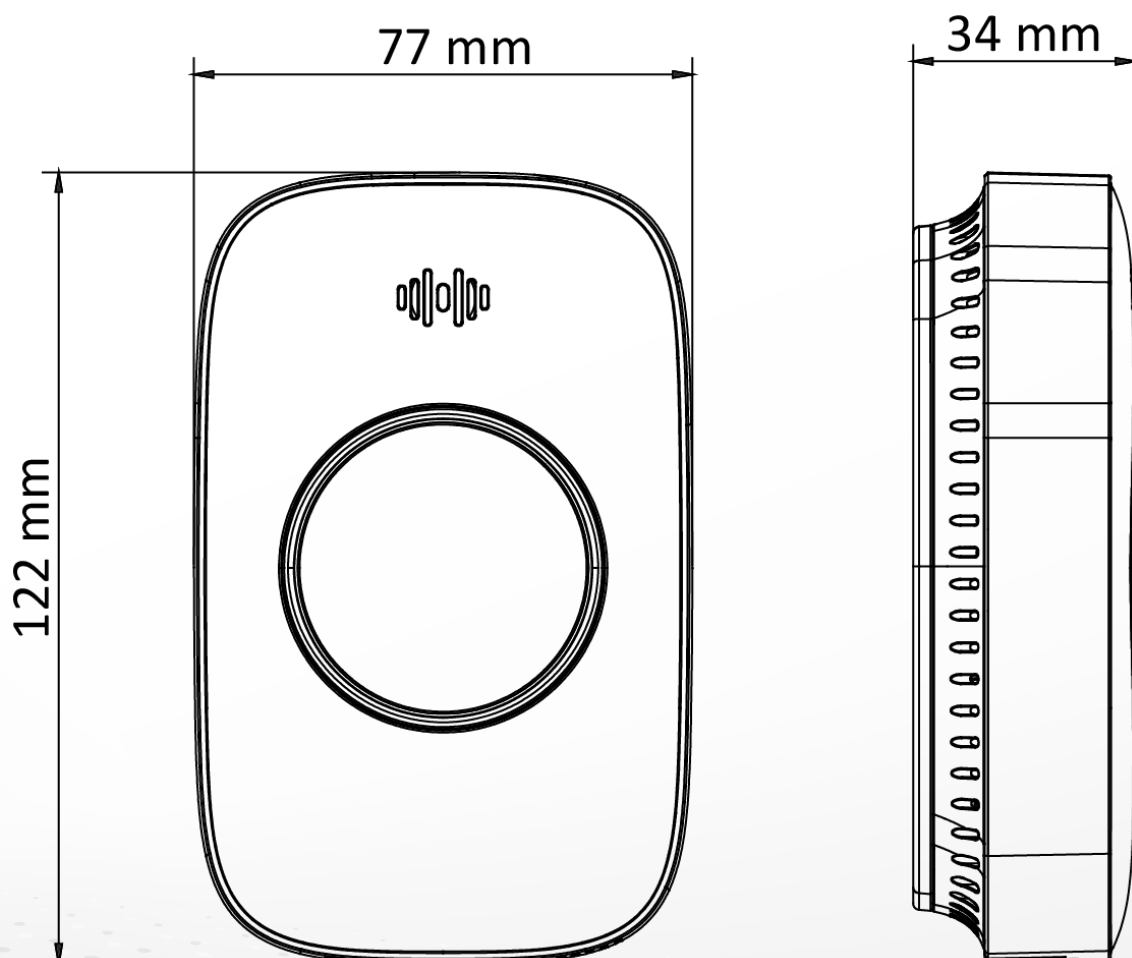

See Far, Go Further



www.hikvision.com
support@hikvision.com

